



PRECISE S2
Enjoy a

PRECISE,
RELIABLE,
and EASY
experience!

Portable 3D LiDAR Scanner Scan it. See it. In true color.

Super-high Fix Rate
99.9%

MMATRIX
Enhanced by
the MATRIX ALGORITHM

Think PRECISE!

WWW.PRECISE-GEO.COM
SALES@PRECISE-GEO.COM
@PRECISE-GEO



PRECISE S2

Portable 3D LiDAR Scanner
Scan it · See it · In true color

**Scan Once.
Save 80% of Your Time.**

One sweep. Total coverage.
Instant results—with no second chances needed.

360° Super-Wide FOV

Capture the entire scene in one sweep with
Hybrid Rotating Mirror Technology for instant
full-surround coverage.

Powered by hybrid-solid rotating mirror technology, the PRECISE S2 delivers a 360° ultra-wide field of view. It enables comprehensive, real-time spatial awareness with no directional blind spots – perfect for capturing the full scene.

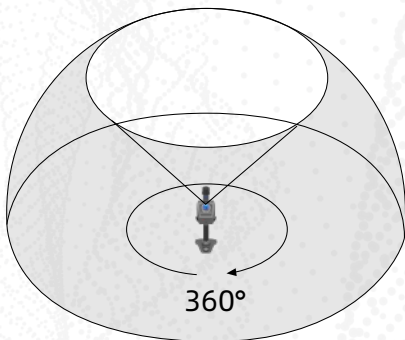

Progressive FOV Expansion

Full coverage in 1 second, outperforms standard multi-line LiDARs with fewer moves.

The PRECISE S2 continuously expands its field of view with each passing second. In just 1 second, it reaches near-total spatial coverage – outperforming typical multi-line mechanical LiDARs limited to fixed vertical FOVs of 27°–41°.

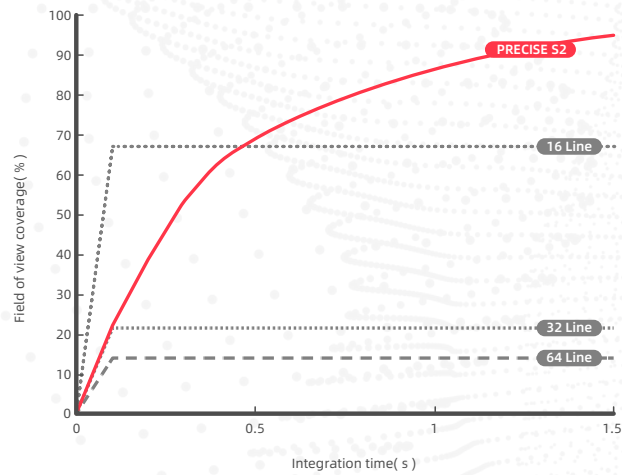
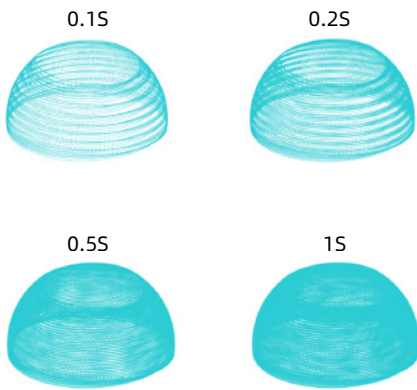

25° Tilted Mounting Angle

Wider coverage. Fewer passes.

The PRECISE S2 is mounted with a 25° downward tilt, enabling it to capture the floor, forward objects, and ceiling in a single scan. This eliminates the need for repeated angle adjustments during operation – greatly improving efficiency in handheld workflows.

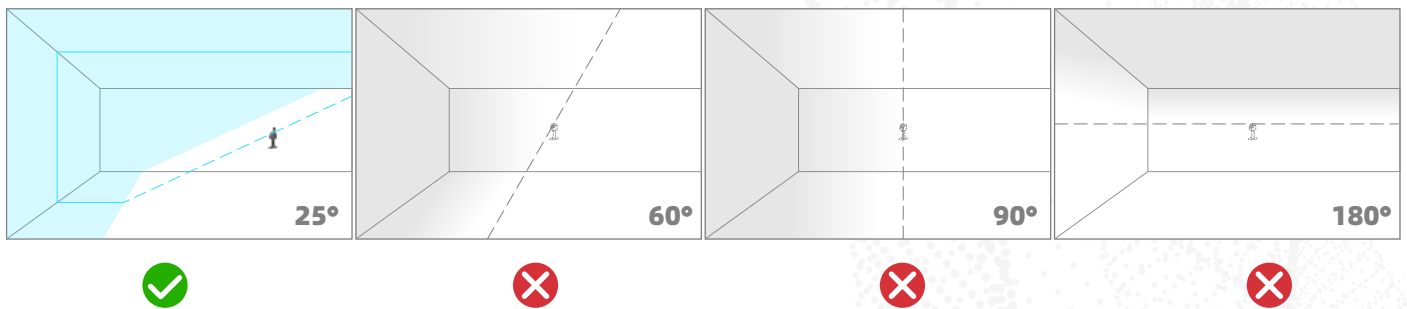

If You Can Walk It, You Can Scan It.

Move freely, scan precisely, no blind spots,
even in GNSS-denied or confined spaces.

10cm Minimum Detection Range

Ultra-Close Detection ensures zero blind spots,
even along walls and in corners.

With a minimum detection range of just 10 cm, the PRECISE S2 excels at identifying nearby objects. Its compact form factor allows flexible mounting and ensures no area goes unseen – even in tight spaces.



150cm

100cm

70cm



40cm

30cm

10cm

Active Anti-Interference

Always on track with no signal interference, even in multi-LiDAR or high-reflection environments.

Engineered with advanced anti-interference capabilities, the PRECISE S2 delivers stable performance even in multi-lidar environments. Indoors or out, it stays focused – unaffected by overlapping signals.

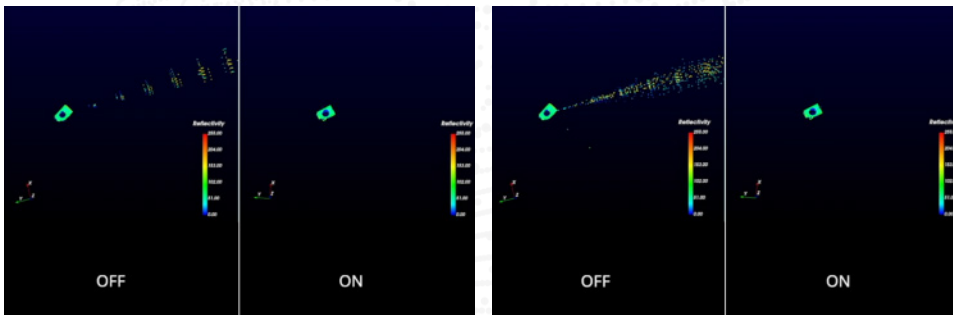

Built-in High-Frequency IMU

More stable scans. More precise models.

Equipped with a 6-axis IMU (3-axis accelerometer + 3-axis gyroscope), the PRECISE S2 delivers high-frequency motion tracking at 200 Hz. This ensures enhanced accuracy in handheld 3D scanning, even during movement or complex scenes.



Scan Today. Model Today.

Dual 1-inch sensors and precise sync deliver crisp, colorized scans, ready to use, wherever your data goes.

Dual 1-Inch Image Sensors

Sharper photos. More vivid point clouds.

Equipped with dual 1-inch CMOS sensors featuring 2.4µm pixels and 16MP resolution per lens, the PRECISE S2 captures clearer, high-fidelity images – enabling more accurate and vibrant point cloud coloring. Together, the dual cameras provide a combined field of view of 270° horizontally and 360° vertically, ensuring full-scene coverage from ground to ceiling.

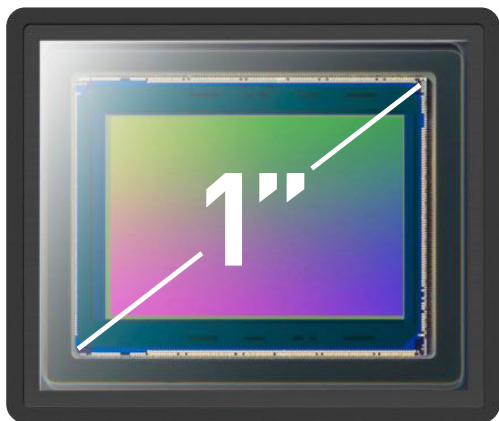

Sharper Point Clouds, Perfectly Fused

Cleaner visuals. Greater precision.

With microsecond-level time synchronization across all sensors, PRECISE S2 delivers highly accurate point clouds where color and intensity data align seamlessly – improving modeling precision and visual clarity.



High-Fidelity SLAM by Design

Richer data. Smarter mapping.

PRECISE's proprietary LiDAR + vision SLAM delivers ultra-dense, real-time point clouds with vibrant, consistent coloring. Robust to motion and scene variation, it's ready for the toughest indoor and outdoor environments.



Real-Time Preview, Precision Results

What you see is what you get.
Anywhere, anytime.

PRECISE S2 comes with a dedicated mobile app for Android, enabling real-time preview of true-color point clouds directly on your phone. During scanning, users can stream, download, and replay point cloud data – all in the palm of their hand.



Small, Simple, Powerful. All Day Long.

High-precision scanning in a compact form—just one device,
one person, zero downtime.

Ultra-Light. Ultra-Mobile

Just 1 kg—built for handheld scanning.

Designed for true mobility, PRECISE S2 weighs only around 1 kg—small enough to navigate narrow spaces, light enough for long shifts without fatigue. Whether handheld or carried on your shoulder, it's ready for fast-paced, go-anywhere scanning.

As Easy as a Photo. Smarter Than Ever

Tap to scan. Always up to date.

No laptop. No cables. Just open the app on your phone or tablet and scan like you're taking a photo. With over-the-air firmware updates and no need for factory recalibration, PRECISE S2 stays ready anytime, anywhere—zero downtime, full autonomy.



Power Through the Day. No Interruptions

Hot-swap and keep going.

With 2.5 hours of tested runtime and USB-C power bank support, you can keep scanning without a pause. Connect external power on the fly to extend operation time, with no need to restart—perfect for long days in the field and back-to-back jobs with no room for failure.



One S2. Many ScanStations Replaced

Survey-grade detail with 40-line density and ≤ 1 cm accuracy.

PRECISE S2 delivers the precision and coverage of multiple tripod-based scanners—all in a single, compact unit. Capture high-density, colored point clouds for BIM, security, and routine surveys—while cutting down on gear, setup time, and field crew.

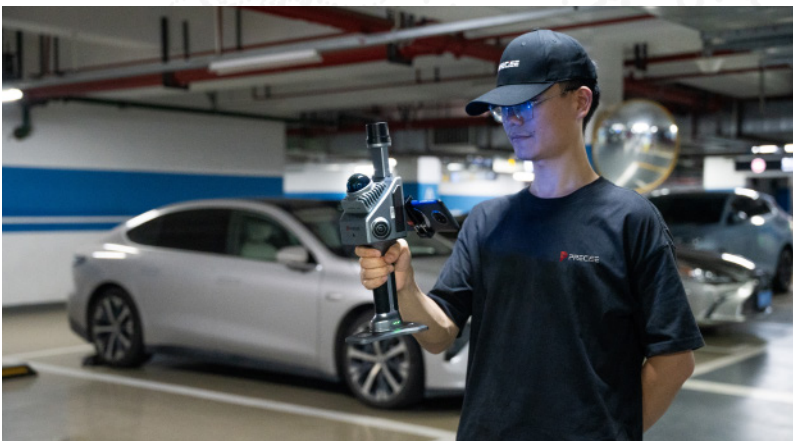

Post-Processing Powerhouse

From scan to model – ready for your workflow.

Mesh-Ready Raw Data

Your data, your pipeline.

Full access to original scan and image data enables mesh modeling through custom SLAM integration – ideal for surveying, inspection, and digital twin applications.

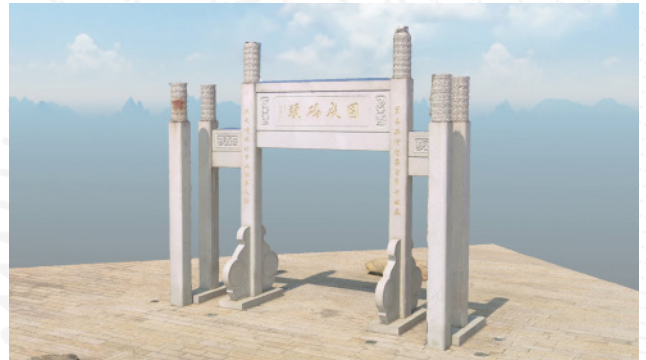

Optimized for 3DGS Modeling

Sharper images, better reconstruction.

With a 1-inch sensor and embedded pose encoding, photos are sharp, color-accurate, and precisely aligned – perfect for high-fidelity 3DGS reconstruction.



Direct BIM/CAD Integration

Point clouds that fit right in.

Point clouds flow seamlessly into BIM and CAD platforms, accelerating accurate drafting and streamlining post-processing workflows.

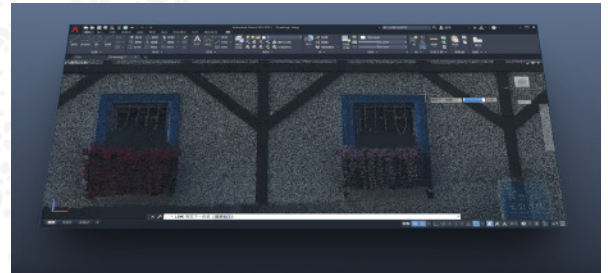

Free Point Cloud Processing Software

No extra fees. No limits.

PRECISE S2 includes a full-featured point cloud software suite at no extra cost. Users can view, edit, replay, and export colored point clouds – without subscription fees or added expenses.



Technical Specifications

Basics

Weight	Main Unit: 700 g Grip Battery: 379 g Overall: 1079 g
Protection Class	IP5X
Working Temperature	-30 °C to 65 °C
Storage Temperature	-40 °C to 70 °C
WIFI	WIFI 6, Support 2.4G/5G 802.11 a/b/g/n/ac/ax Wi-Fi 2.4G: 2.400 ~ 2.4835 GHz 5G: 5.15 ~ 5.35GHz, 5.47 ~ 5.725GHz 5.725 ~ 5.85GHz
WIFI Distance	20 m
Bluetooth	Support
Dimensions	Overall: 110.5 * 140 * 313.3mm; Main Unit : 110.5 * 114 * 143.1mm
Storage Capacity	256 G(Support memory expansion)
Supply Voltage	13.2 V ~ 16.8 V
Working Power	< 24 W
Interface	TF Card slot / Type-C
Processor Performance	8-core 64-bit processor, clock speed 2.4 GHz

RTK

RTK Accuracy	Horizontal 0.8 cm + 1 ppm; Vertical 1.5 cm + 1 ppm
Supported Regions	China / Overseas
Support Satellite	BDS: B1I, B2I, B3I, B1C, B2a, B2b GPS: L1C/A, L1C, L2C, L2P(Y), L5 GLONASS: L1, L2, L3 Galileo: E1, E5a, E5b, E6 QZSS: L1C/A, L1C, L2C, L5 NavIC: L5 SBAS: L1

Camera

Sensor Size	13.13 * 8.76 mm; 1 inch
Pixel Size	2.4 μm
Image Size	3504 * 4672 pixels
Effective Pixels	Single lens 16 million
Shutter Type	Mechanical shutter; Electronic shutter
Aperture	Fixed F2.8
Focal Length	3.5 mm
Lens Number	2
Lens FOV	Horizontal: 140° Vertical: 200°
Image Format	JPG

V-SLAM Camera

Focal Length	1.68 mm
Image Pixel	1280 * 800
Effective Pixels	1 million
Frame Rate	30 HZ

Battery

Battery Capacity	45.36 wh (3150 mAh)
Supply Voltage	14.8 V ~ 16.8 V
Working Time	150 min
Charging Port	Type-C
Charging Power	PD 30 W
Charging Time	120 min

Data & Software

Point Cloud Thickness	≤ 1 cm
Relative Accuracy	≤ 2cm
Absolute Accuracy	≤ 5cm





Think PRECISE!

WWW.PRECISE-GEO.COM / SALES@precise-geo.com / [@PRECISE-GEO](https://www.instagram.com/PRECISE-GEO)

